

HANG GLIDER TARGET

MANUAL

Size: _____

Manufactured by:

*AEROS Ltd.
Post-Volynskaya St. 5.
Kiev, 03061
UKRAINE*

*Tel: (380 44) 455 41 18
Fax: (380 44) 455 41 16
E-mail: aerosint@aerosint.kiev.ua
<http://www.aeros.com.ua>*

Date of production: _____

Serial number: _____

TABLE OF CONTENTS

Section 1.	Main Information.....	2
1.1.	Introduction.....	2
1.2.	Technical Information.....	2
1.3.	Flight Limitations.....	3
Section 2.	Set Up Procedure.....	4
2.1.	Set Up Procedure From The Package 2-m Long.....	4
2.2.	Set Up Procedure From The Package 6-m Long.....	15
2.3.	Set Up Procedure From The Package 4-m Long.....	20
2.4.	Preflight Inspection Of The Glider.....	21
2.5.	Laying The Glider Flat.....	25
Section 3.	Performance of the Flight.....	26
3.1.	Preparation for Flight.....	26
3.2.	Launching.....	26
3.3.	Flying.....	26
3.4.	Turning.....	26
3.5.	Landing.....	26
Section 4.	Breakdown	27
4.1.	Breakdown Into the Package 6m Long.....	27
4.2.	Breakdown Into the Package 4m Long.....	29
4.3.	Breakdown Into the Package 2m Long.....	30
Section 5.	Maintenance.....	33
5.1.	Tuning.....	33
5.2.	Periodical Inspection.....	34
5.3.	Maintenance.....	35
5.4.	Storage.....	35
5.5.	Transportation.....	35
Section 6.	Sail height measurement.....	36
Section 7.	Owners notes.....	37
Section 8.	List of Spare Parts.....	38
Section 9.	Page of change and addition.....	39
Section 10.	Schemes.....	42

Section 1. MAIN INFORMATION

1.1. INTRODUCTION

Hang glider "Target" was created by a design team of Aeros Ltd. Its birth is a result of extensive design and improvement of the glider, aimed for those who make a first steps in the sky.

Hang glider "Target" allows you to train with a maximum level of safety. With this glider you will acquire right skills of handling and confidence in your qualification and also receive a real pleasure of soaring.

Please read and be sure you thoroughly understand this manual before flying your "Target". Don't try to make first flights without help of instructor or HG-school. If you don't know where to find HG-school in your region - ask your dealer or your national HG-club.

Be sure you are thoroughly familiar with the set up, break down, preflight and maintenance procedures as described in this manual. Flying hang glider, don't leave anything without check. If any doubts appear - stop your work and find out what's wrong, check with manual, contact instructor or more experienced pilot.

1.2. TECHNICAL INFORMATION

	TARGET 13	TARGET 16
Sail area, sq.m. (sq.ft)	13,4 (144)	16,2 (174)
Wing span, m. (ft)	8,65 (28.4)	9,6 (31.5)
Aspect ratio	5,6	5,7
Nose angle, deg	118	120
Pilot weight optim, kg (lbs)	60 (132)	75 (165)
Weight (without bags), kg (lbs)	24,5 (54)	26 (57.3)
Breakdown length, m	5,1 / 3,2 / 2,0	5,7 / 3,8 / 2,0
Min sink rate m/sec (fpm)	1,1 (216)	1,1 (216)
Glide ratio	7	7+

1.3. FLIGHT LIMITATIONS

Hang glider "Target" is designed for foot launching and for educational and training flights. It was not designed to be motorized and not flown at angles of bank beyond 60 degrees. Operation in any of these modes may severely compromise your safety.

Flying any hang glider in the presence of turbulence or gusty winds can result in accident. Don't fly in such conditions.

	TARGET 13	TARGET 16
Wind speed max, m/s (mph)	12 (27)	12 (27)
Take off altitude max, m	2500	2500
Permissible range of temperature, °C	-20 ... +40	-20 ... +40
Minimum airspeed, km/h (mph)	26 (16)	24 (15)
Maximum airspeed, km/h (mph)	70 (44)	70 (44)
Minimum pilot weight, kg (lbs)	45 (99)	60 (132)
Maximum all up pilot weight, kg (lbs)	75 (165)	100 (224)

Hang glider "Target" passed all structural and flight tests in the British Hang and Paragliding Association (BHPA) and admitted to exploitation as hang glider for beginners.

Certificate of BHPA :
No.9511108 (for Target 16)
No.9511109 (for Target 13)

Your hang glider "Target" was tested on: _____

by: _____

Section 2. SET UP PROCEDURE

2.1. SET UP PROCEDURE FROM THE PACKAGE 2m LONG

2.1.1. Undo the cord securing the package. Remove the bag 2-metres long.

2.1.2. Undo and remove securing tapes, unfold the bag 6-metres long.

2.1.3. Place completing parts of the frame with comfort (Fig.1). Undo the zipper on the bag and move the sail.

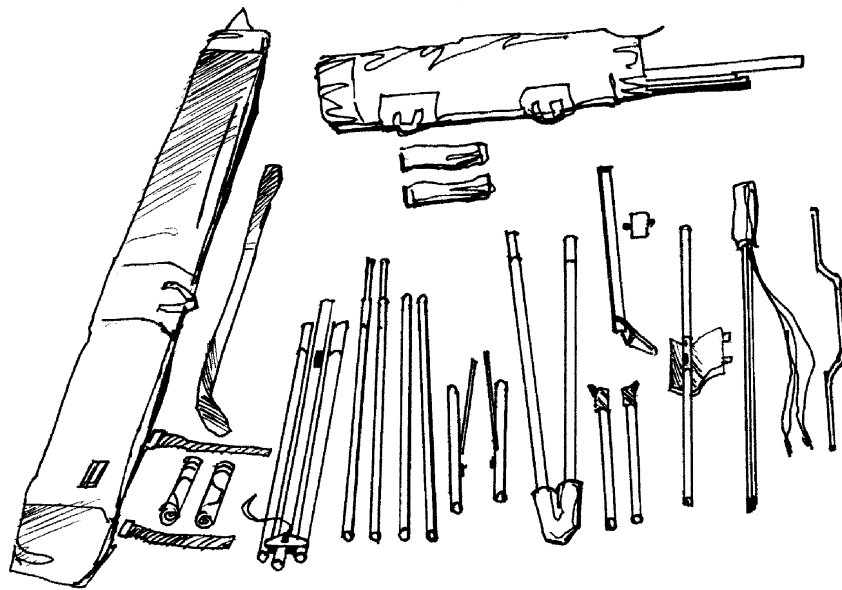

Fig.1

2.1.4. Remove protective bag from the bottom of uprights. Spread the uprights. Install the speedbar so that off-set of the speedbar is directed forward and upwards to the flight direction (in the same direction as bottom front wires with the hook). (Fig.2).

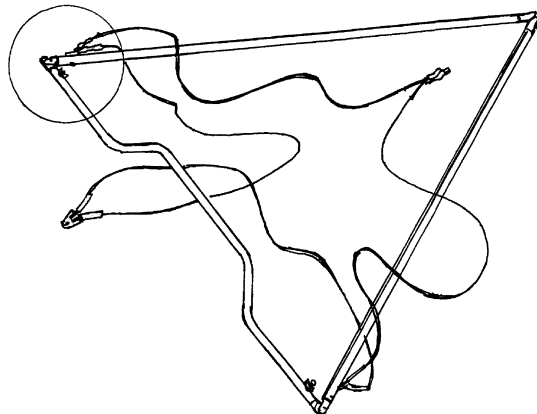

Fig.2

If your glider is supplied with wheels, secure wheels on the speedbar now. Fix the speedbar using the bolts, wing nuts and the safety rings (Fig.3) or using quick-pins.

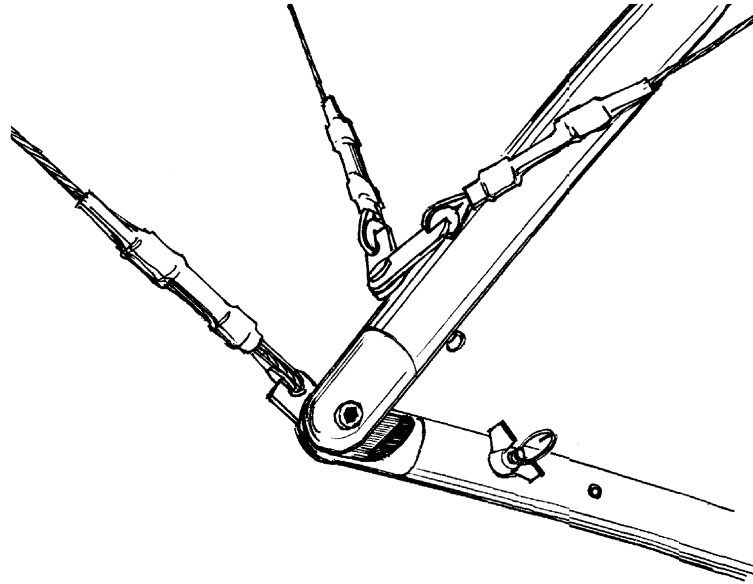

Fig.3

2.1.5. Lay the N1 keel tube with N1 leading edge tubes so that the channel which secures the control bar is above. Attach the uprights to the channel using the bolt which is put through the channel and through the tops of the downtubes and fix them with the nut and the safety ring (Fig.4).

NOTE: Pay attention to the proper installation of the downtubes. Bottom front wires with the hook must be on the top.

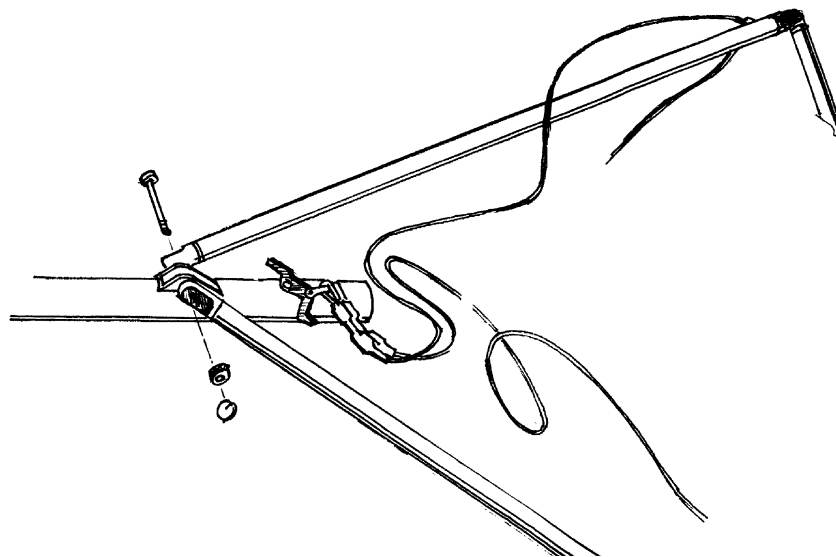

Fig.4

2.1.6. Turn the front part of the frame with uprights so that the channel which secures the kingpost is on top. Attach the N2, N3 and N4 leading edge tubes using the telescopic connectors which are fixed with button springs. While performing the set up procedure of the leading edge keep to the following marking: L-left, R-right (Fig.5). Tubes N4 fix with the pin secured by the safety rings. Washout tips must be directed as shown in Fig.5a. Check that the tube junction in the telescopic connectors are secure.

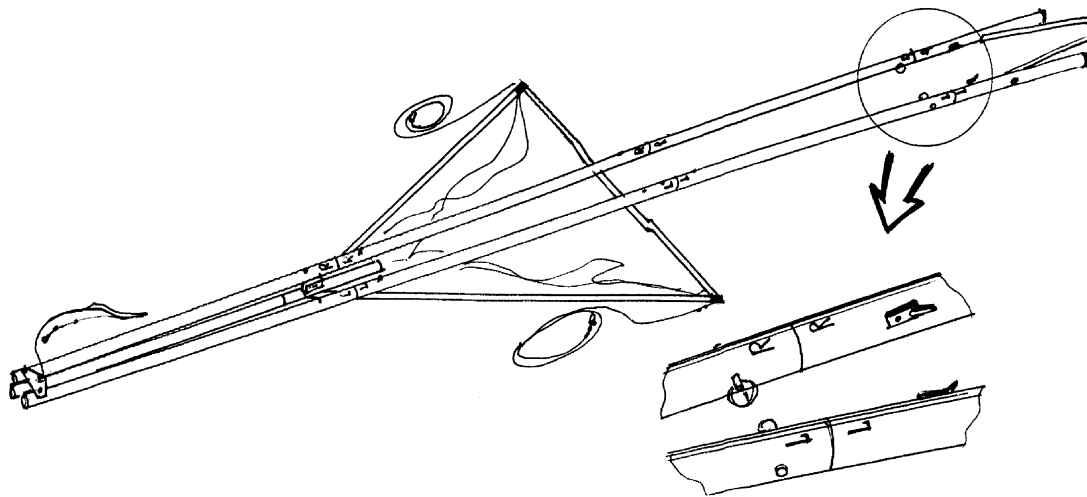

Fig.5

2.1.7. Set up the crossbar: attach the N2 tubes to the N1 tubes of the crossbar, keeping to the following marking: L-left, R-right. Fix the junction with the button springs.

2.1.8. Lay and spread the sail. Spread the leading edge of the sail so that there are no folds and bends in it. Pushing the mylar by both edges insert it into the leading edge pocket. Bow - shaped edge of the mylar must pass on the side of the seam that joins the top and bottom surface and the leading edge of the sail (Fig.7).

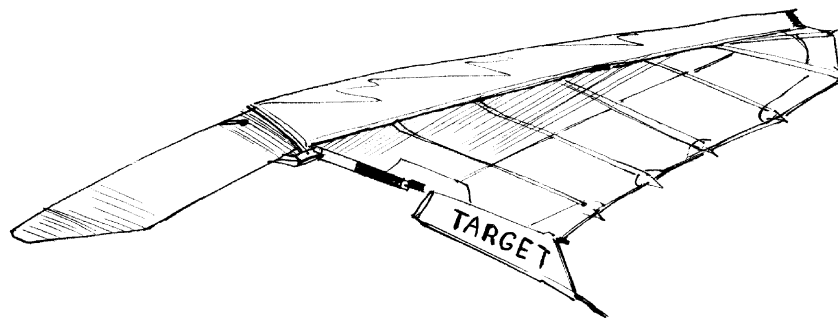

Fig.6

It's more easy to pull last 20-30 cm by your hand using a chink between the leading edge and top surface of the sail on the wing tips. (Fig.7).

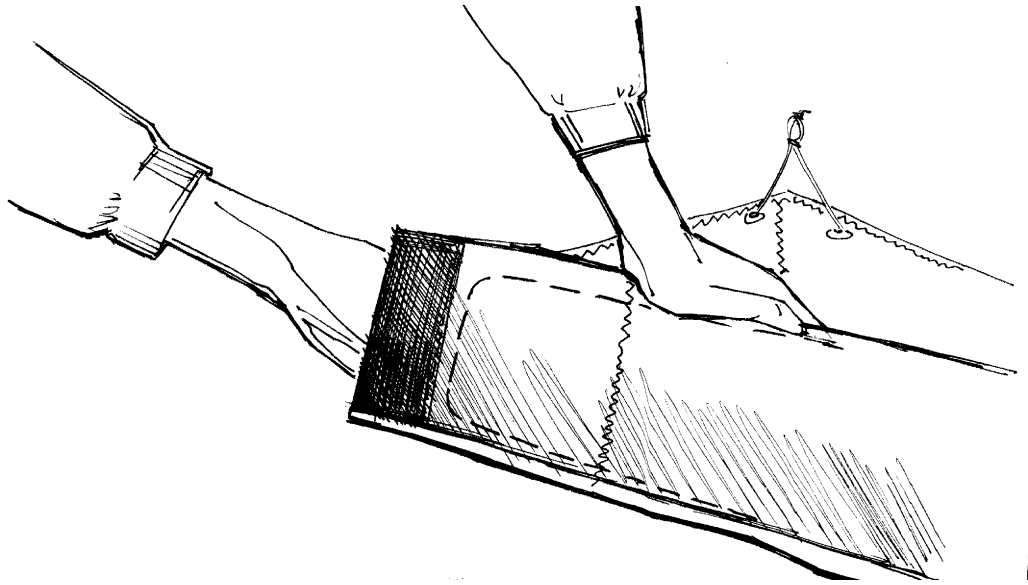

Fig.7

2.1.9. Place the A-frame nose to the wind.

Lay the sail nose to the console ends (Fig.8).

Lift slightly the leading edge tubes and insert them into the sail (Fig.9). Make sure that leading edge tubes pass properly into the sail, not in the holes for cross-bar. Keel tube must be out of the sail.

Insert washout tips into corresponding holes in the sail.

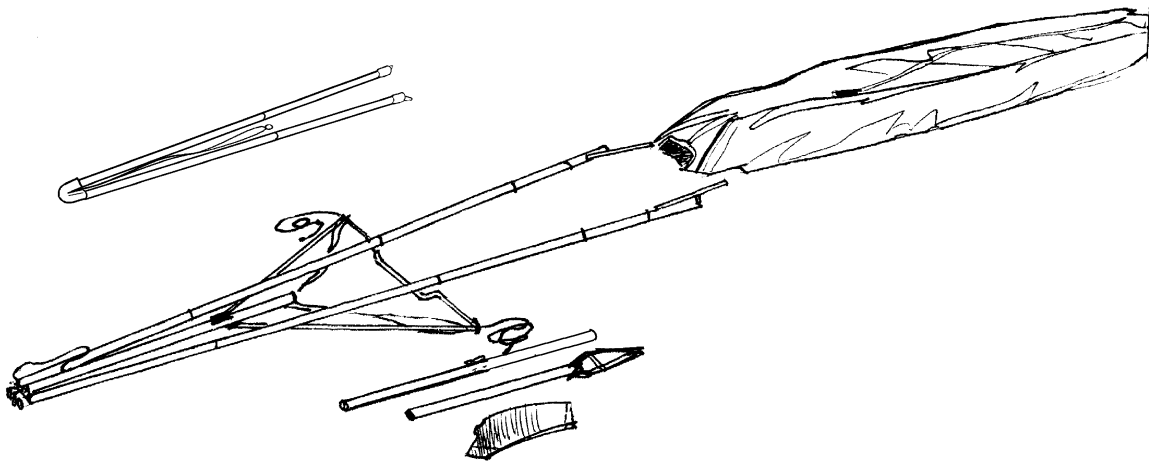

Fig.8

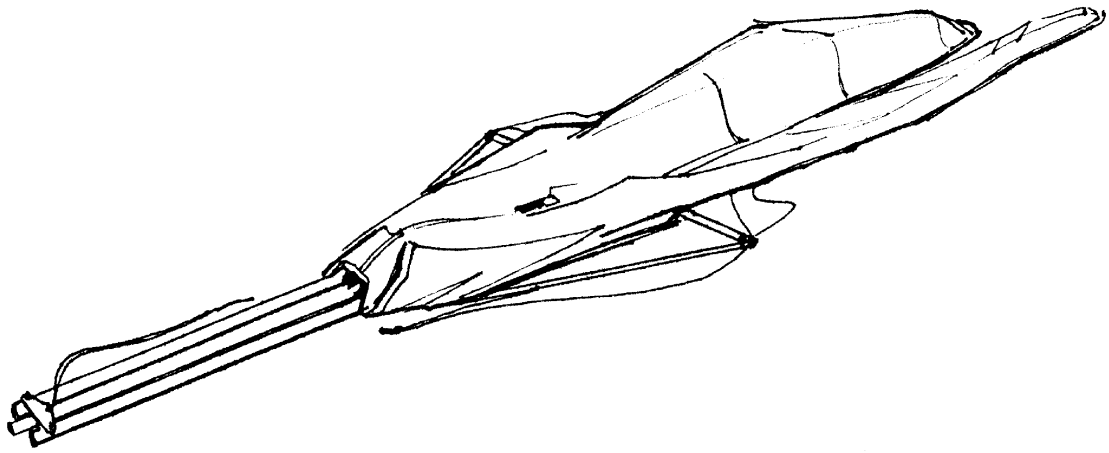

Fig.9

2.1.10. Spread wings about quarter way and lift slightly the sail above the keel tube. Put the crossbar on the keel tube so that crossbar tensioning wires pass through the channel of the kingpost. The plates of leading edge/crossbar junction, should be near corresponding holes in the leading edge (Fig.10).

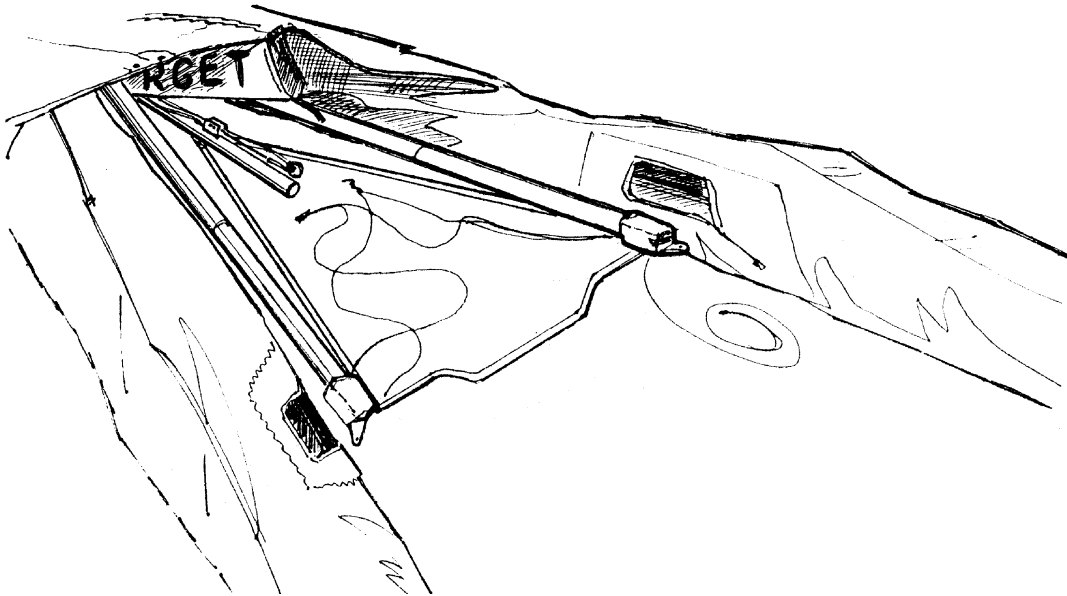

Fig.10

2.1.11. Put the hang strap which is on the kingpost through the kingpost hole in the sail and fit it over the end of N1 keel tube so that the spreader bar of the hang strap is under the keel tube. Install the kingpost into the kingpost channel. **Make sure that crossbar tensioning wire pass through the kingpost channel.** Secure the kingpost with the clevis pin and the safety ring (Fig.11).

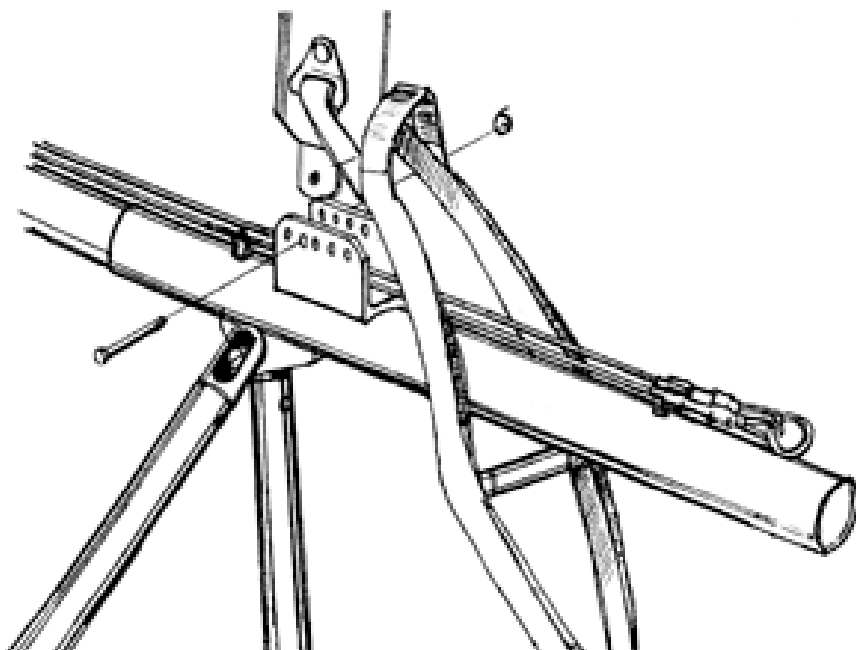

Fig.11

On your hang glider Serial No. _____ kingpost secures in the channel through the hole No. _____ (Fig.12) for a pilot of _____ kg weight.

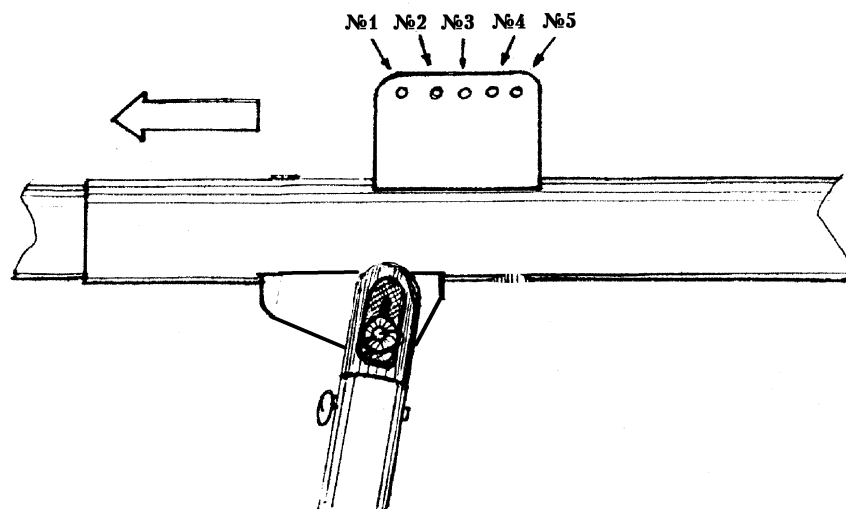

Fig.12

2.1.12. Insert the keel tube N2 into the keel pocket and attach it to the N1 part, pressing on the button spring and pushing the tube.

2.1.13. Put the top front wire through the corresponding hole at the nose of the sail. Put the tightening rope of the nose of the sail under the front end of the keel tube (Fig.13).

Insert the keel batten into the keel batten pocket beginning from the nose of the sail.

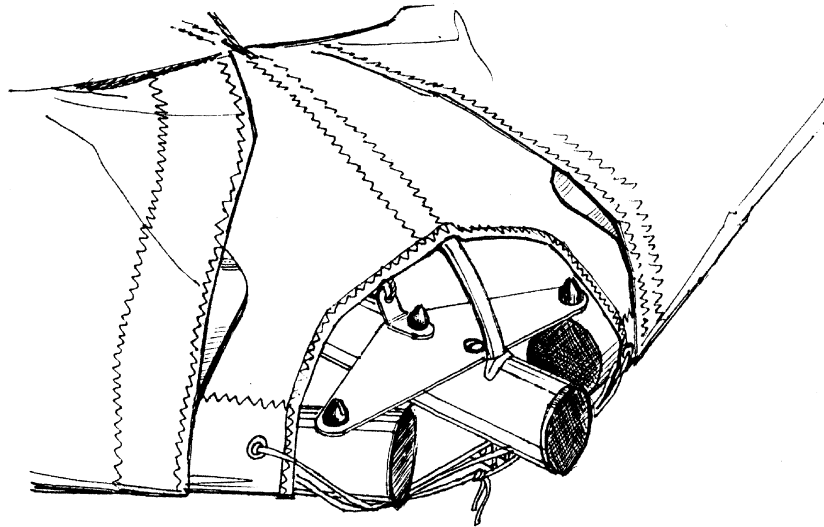

Fig.13

2.1.14. Insert the top side wire in the kingpost cap slots, then insert the top front wire. Install the cap cover which fixes the wires (Fig.14).

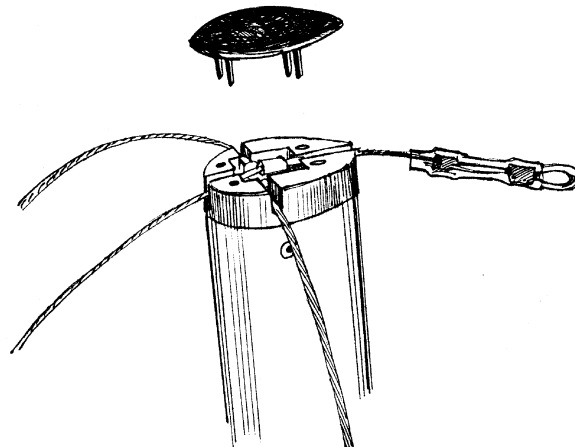

Fig.14

2.1.15. Put the top and bottom side wires through the corresponding holes in the sail. Undo the zippers on the bottom surface near the leading edge/crossbar junction and check that the wires pass through the holes.

NOTE: There are usually the bolt of the crossbar/leading edge junction with the standoff and fluoroplastic washer, the nut and the safety ring on the tang of the bottom side wires. Take them away from the tang before putting the wire through the holes in the sail.